

The LF01 is a flangeless, mud-over extrusion that features a regressed lens, expertly designed to minimize glare and surface brightness. This creates elegant, discreet light lines that blend seamlessly into a variety of architectural styles, offering a sophisticated lighting solution that enhances the ambience without overpowering the space.

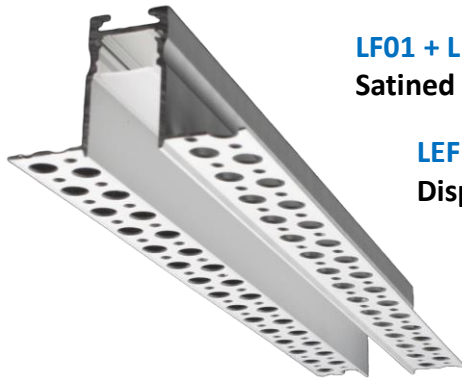

**LF01 + LEF15-SL**  
Satined Lens

**LEF15-SLD**  
Disposable Lens

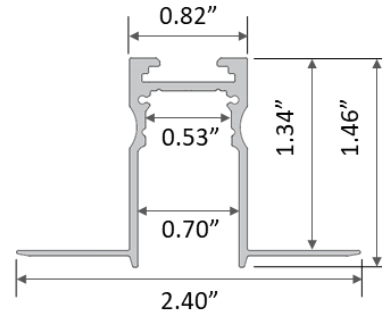

**LF01-EC**  
End Cap



**LZ98-CN180**  
Connector



**LZ98-CN90**  
90° Connector



**LZ98-VC90**  
90° Vertical Connector

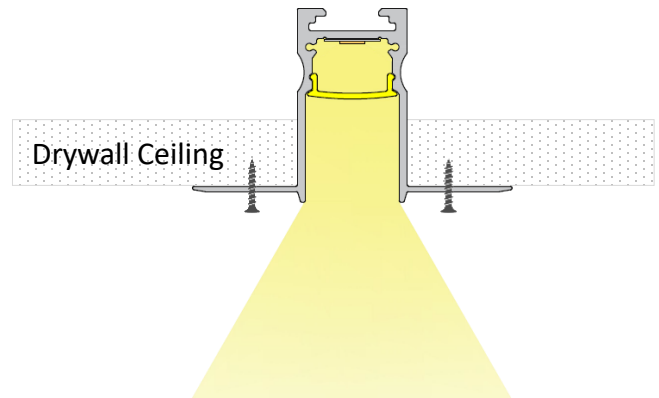

## Product Detail

Material:	Extruded Aluminum
Color:	Anodized Silver
Dimension (in):	L 78.74" x W 2.40" x H 1.46"
Customization:	Cut to specified length

## Applications

- |  |                                     |
|--|-------------------------------------|
| <input type="checkbox"/> Recessed Flangeless | <input type="checkbox"/> Accents    |
| <input type="checkbox"/> Regressed Light     | <input type="checkbox"/> Bathroom   |
| <input type="checkbox"/> Indirect Lighting   | <input type="checkbox"/> Dining     |
| <input type="checkbox"/> Hallways            | <input type="checkbox"/> Healthcare |
| <input type="checkbox"/> Retail              | <input type="checkbox"/> Offices    |

## Compatible LED Tapelight

Product	Output (lm/ft)	LEDs/ft	Consump. (watt/ft)	Efficacy (lm/watt)	CRI	Voltage	Max Length	Min Cut
---------	----------------	---------	--------------------	--------------------	-----	---------	------------	---------

### Florence (Specification Grade)

L90	~ 90	36	~ 0.73	~ 123	>90	24V	75'	1.97"
L200	~ 200	36	~ 1.46	~ 140	>90	24V	49'	1.97"
L360	~ 360	36	~ 3.12	~ 117	>90	24V	42'	1.97"
L500	~ 500	36	~ 4.39	~ 135	>90	24V	36'	1.97"
L780	~ 780	36	~ 6.72	~ 108	>90	24V	24'	1.97"
L990	~ 990	36	~ 9.36	~ 106	>90	24V	16'	1.97"
RGB-3535	~ 170	36	~ 4.4	~ 39	N/A	24V	23'	1.97"
RGB-3838	~ 280	73	~ 5.0	~ 56	N/A	24V	16'	1.00"
RGB-5050	~ 230	29	~ 7.0	~ 23	N/A	24V	13'	2.46"
RGBW	~ 330	29	~ 7.3	~ 47	N/A	24V	13'	2.46"
TW1865	~ 60-850	73	~ 5.8	~ 10-146	>90	24V	16'	1.97"
TW2740	~ 210-430	73	~ 5.8	~ 36-74	>90	24V	16'	1.97"
Dim-To-Warm	~ 168	73	~ 4.4	~ 38	>90	24V	16'	1.97"

### Athens (Economy)

L240	~ 240	36	~ 2.29	~ 115	>90	24V	39'	1.97"
L460	~ 460	36	~ 4.27	~ 115	>90	24V	26'	1.97"
L680	~ 680	36	~ 6.40	~ 105	>90	24V	20'	1.97"

## Compatible SOB Tapelight

Product	Output (lm/ft)	IP Rating	Consump. (watt/ft)	Efficacy (lm/watt)	CRI	Voltage	Max Length	Min Cut
---------	----------------	-----------	--------------------	--------------------	-----	---------	------------	---------

### Coblence H (High CRI)

L195	~ 195	IP20	~ 2.93	~ 80	>97	24V	49'	1.97"
L220	~ 220	IP67	~ 2.93	~ 80	>97	24V	65'	1.97"
L325	~ 325	IP67	~ 4.88	~ 70	>97	24V	32'	1.16"

### Coblence S (Specification Grade)

L280	~ 280	IP20	~ 2.93	~ 100	>90	24V	49'	1.97"
L335	~ 335	IP67	~ 2.93	~ 120	>90	24V	65'	1.97"
L465	~ 465	IP67	~ 4.88	~ 100	>90	24V	32'	1.16"







## Ordering Code: LF01 + Tapelight + Accessories + Lengths

LF01	- SL	- F	- L200	IP00	CT35	- EC	- CN	- 4'				
Extrusion	Lens	Tapelight				End Cap	Connector	Length				
LF01	SL – Satined Lens	F – Florence	L090	~90 lm/ft	IP00	CT27	2700K	EC – End Cap	CN180 – Linear Connector	Enter run length		
			L200	~200 lm/ft		CT30	3000K					
	L360		~360 lm/ft	IP66	CT35	3500K						
	L500		~500 lm/ft		CT40	4000K						
	L780		~780 lm/ft									
	L990		~990 lm/ft									
			RGB-3535	RGB	IP20	N/A						
			RGB-3838	RGB	IP54							
			RGB-5050	RGB	IP20	N/A						
			RGBW	RGBW	IP00	N/A						
		TW1865	TW	IP00		1800-6500K						
		TW2740	TW		IP65		2700-4000K					
		DTW	Dim-To-Warm	IP00	CT2130	2100-3000K						
				IP54								
		A – Athens	L240	~240 lm/ft	IP00	CT27	2700K					
			L460	~460 lm/ft		IP66	CT30	3000K				
			L680	~680 lm/ft		CT35	3500K					
					CT40	4000K						
		CH – Coblence H	L195	~195 lm/ft	IP20	CT27	2700K					
			L220	~220 lm/ft	IP67	CT30	3000K					
			L235	~235 lm/ft	IP67	CT35	3500K					
					CT40	4000K						
		CS – Coblence S	L280	~280 lm/ft	IP20	CT27	2700K					
			L335	~335 lm/ft	IP67	CT30	3000K					
			L465	~465 lm/ft	IP67	CT35	3500K					
					CT40	4000K						

CN90 – 90° Connector

VC90 – 90° Vertical Connector

## Power Supply Ordering Codes

DTR		+	60		+	IP67		DTR60IP67 - Dimming, 60 Watt, IP67					
MODEL		+	POWER		+	IP RATING		INPUT	OUTPUT	DIMENSION			
<b>NTR</b> Non-Dimming [UL Recognized]			<b>50</b>	50 Watt		<b>IP00</b> Indoor	88-264V	24V	3.90 x 3.82 x 1.42				
		<b>75</b>	75 Watt	5.08 x 3.82 x 1.50									
		<b>100</b>	100 Watt	6.26 x 3.82 x 1.50									
		<b>150</b>	150 Watt	7.84 x 3.85 x 1.50									
		<b>200</b>	200 Watt	8.46 x 4.53 x 1.18									
		<b>320</b>	320 Watt	8.46 x 4.53 x 1.18									
		<b>750</b>	750 Watt	9.84 x 5.00 x 1.61									
		<b>960</b>	960 Watt	11.60 x 5.00 x 1.61									
		<b>12</b>	12 Watt						<b>IP42</b> Indoor	90-264V	24V	3.03 x 1.57 x 1.14	
		<b>16</b>	16 Watt									3.03 x 1.57 x 1.14	
	<b>25</b>	25 Watt	3.31 x 2.24 x 1.16										
	<b>35</b>	35 Watt	3.31 x 2.24 x 1.16										
	<b>20</b>	20 Watt		<b>IP67</b> Outdoor	90-264V	24V	4.65 x 1.38 x 1.02						
	<b>35</b>	35 Watt					5.83 x 1.57 x 1.18						
	<b>60</b>	60 Watt					6.40 x 1.67 x 1.26						
	<b>100</b>	100 Watt					7.48 x 2.05 x 1.46						
	<b>150</b>	150 Watt					7.52 x 2.48 x 1.48						
	<b>240</b>	240 Watt					9.61 x 2.68 x 1.53						
	<b>320</b>	320 Watt	9.92 x 3.54 x 1.72										
<b>DTR</b> Dimming min 10% (0-10V) [UL Recognized]		<b>16</b>	16 Watt		<b>IP30</b> Indoor	90-305V	24V	5.83 x 1.57 x 1.26					
		<b>25</b>	25 Watt					<b>IP67</b> Outdoor	90-305V	24V	5.83 x 1.57 x 1.26		
		<b>40</b>	40 Watt								6.40 x 1.70 x 1.26		
		<b>60</b>	60 Watt								6.40 x 1.70 x 1.26		
		<b>90</b>	90 Watt								6.34 x 2.40 x 1.42		
		<b>96</b>	96 Watt								8.66 x 2.68 x 1.53		
		<b>120</b>	120 Watt								8.66 x 2.68 x 1.53		
		<b>150</b>	150 Watt								8.97 x 2.68 x 1.58		
		<b>185</b>	185 Watt								8.97 x 2.68 x 1.58		
		<b>240</b>	240 Watt								9.88 x 2.68 x 1.58		
	<b>320</b>	320 Watt	9.92 x 3.54 x 1.72										
	<b>480</b>	480 Watt	10.32 x 4.92 x 1.72										
	<b>600</b>	600 Watt	11.02 X 5.67 X 1.91										
<b>FPD</b> Dimming min 1% (Forward Phase) [UL Recognized]		<b>20</b>	20 Watt		<b>IP67</b> Outdoor	120V	24V	4.92 x 2.20 x 0.79					
		<b>40</b>	40 Watt					4.92 x 2.20 x 0.79					
		<b>60</b>	60 Watt					4.92 x 2.20 x 0.79					
		<b>75</b>	75 Watt					4.92 x 2.20 x 0.79					
		<b>96</b>	96 Watt					4.92 x 2.20 x 0.79					
<b>FPD</b> Dimming min 1% (Forward Phase) with junction box [ETL Listed]		<b>20</b>	20 Watt		<b>IP14</b> Outdoor	120V	24V	5.60 x 2.00 x 2.14					
		<b>40</b>	40 Watt					5.60 x 2.00 x 2.14					
		<b>60</b>	60 Watt					6.62 x 2.58 x 2.33					
		<b>96</b>	96 Watt					6.62 x 2.58 x 2.33					
		<b>150</b>	150 Watt					9.80 x 3.00 x 2.74					
		<b>200</b>	200 Watt					9.80 x 3.00 x 2.74					
	<b>300</b>	300 Watt	10.07 x 4.20 x 3.50										

CUSTOMIZATION	TL48	DC99	LN99	EX99	M99	C99	F48	F48C	IP68
Cutting tapelight to specified length + solder 4ft leadwire	✓						✓	✓	
Daisy Chain: Cut tapelight to specified length + 2", 6", or 12" jumper cable daisy chain between 2 run lengths		✓							
Installing tapelight onto extrusion							✓	✓	
Cutting diffuser to specified length			✓				✓	✓	
Cutting extrusion to specified length				✓			✓	✓	
Miter corner extrusion and diffuser					✓				
Filling extrusion with polyurethane (2 ft submersible)									✓
Customize extrusion to specified color						✓		✓	
Final function and quality inspection	✓	✓	✓	✓	✓	✓	✓	✓	✓